

Tacoma Distribution Center

1525 East D St | Tacoma, WA 98421



Property Details

Located immediately adjacent to the Port of Tacoma with excellent access to Interstate 5, SR-509 and Hwy 99, Tacoma Distribution Center provides a strategic position to service Port, Seattle/Tacoma and the Pacific Northwest Region distribution needs.

| Address | Space Type | Size | Comments |
|----------------|---------------------|---------------------|--|
| 1525 East D St | Mezzanine warehouse | ±117,277 SF | <ul style="list-style-type: none"> + 2 freight elevators + 3rd freight elevator proposed; <ul style="list-style-type: none"> - direct exterior access from truck court - 40' wide x 12' deep x 7' high - 10,000 lb. lifting capacity + Up to 4 dock high loading doors + 14'-20' clear height + BTS office area |
| 1525 East D St | Office | ±24,090 - 48,180 SF | + 24,090 SF on 3rd and 4th floors |

Floor Plans

Mezzanine Warehouse

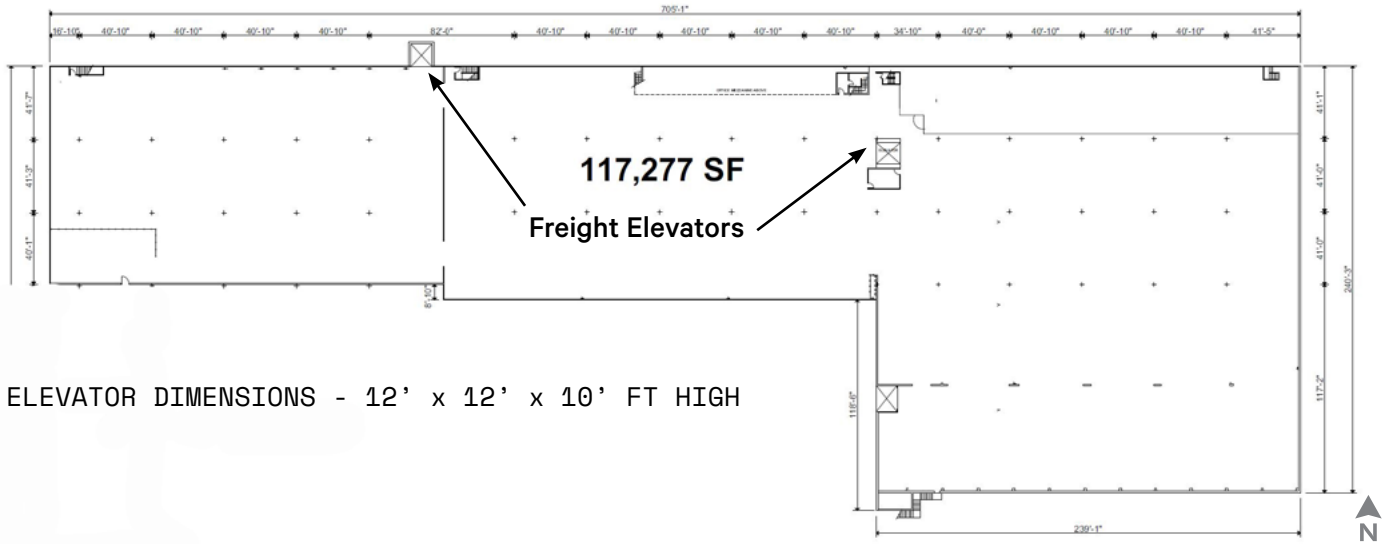

ELEVATOR DIMENSIONS - 12' x 12' x 10' FT HIGH

Third & Fourth Floor Office

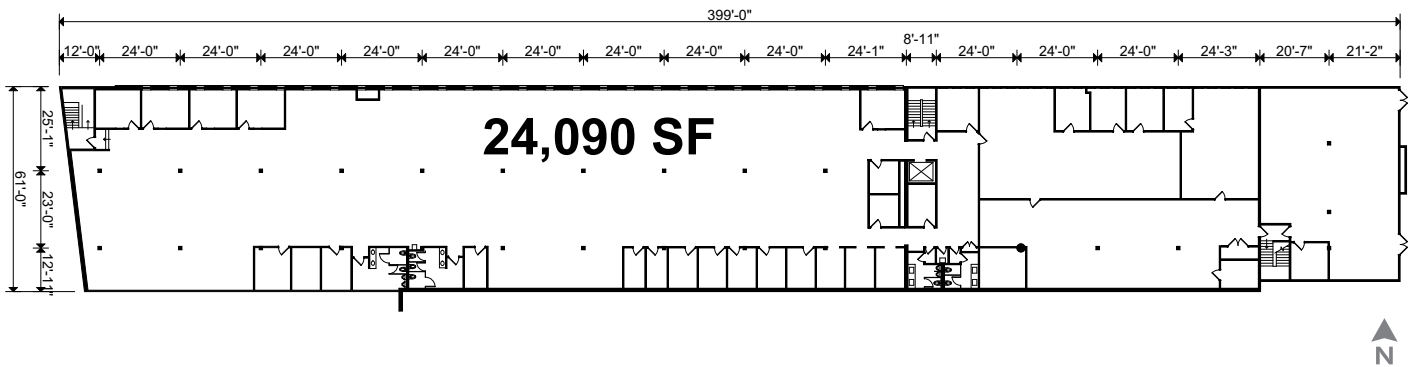

Future 3rd Freight Elevator

FL4M
GENERAL ARRANGEMENT

ROOF
STRUCTURE

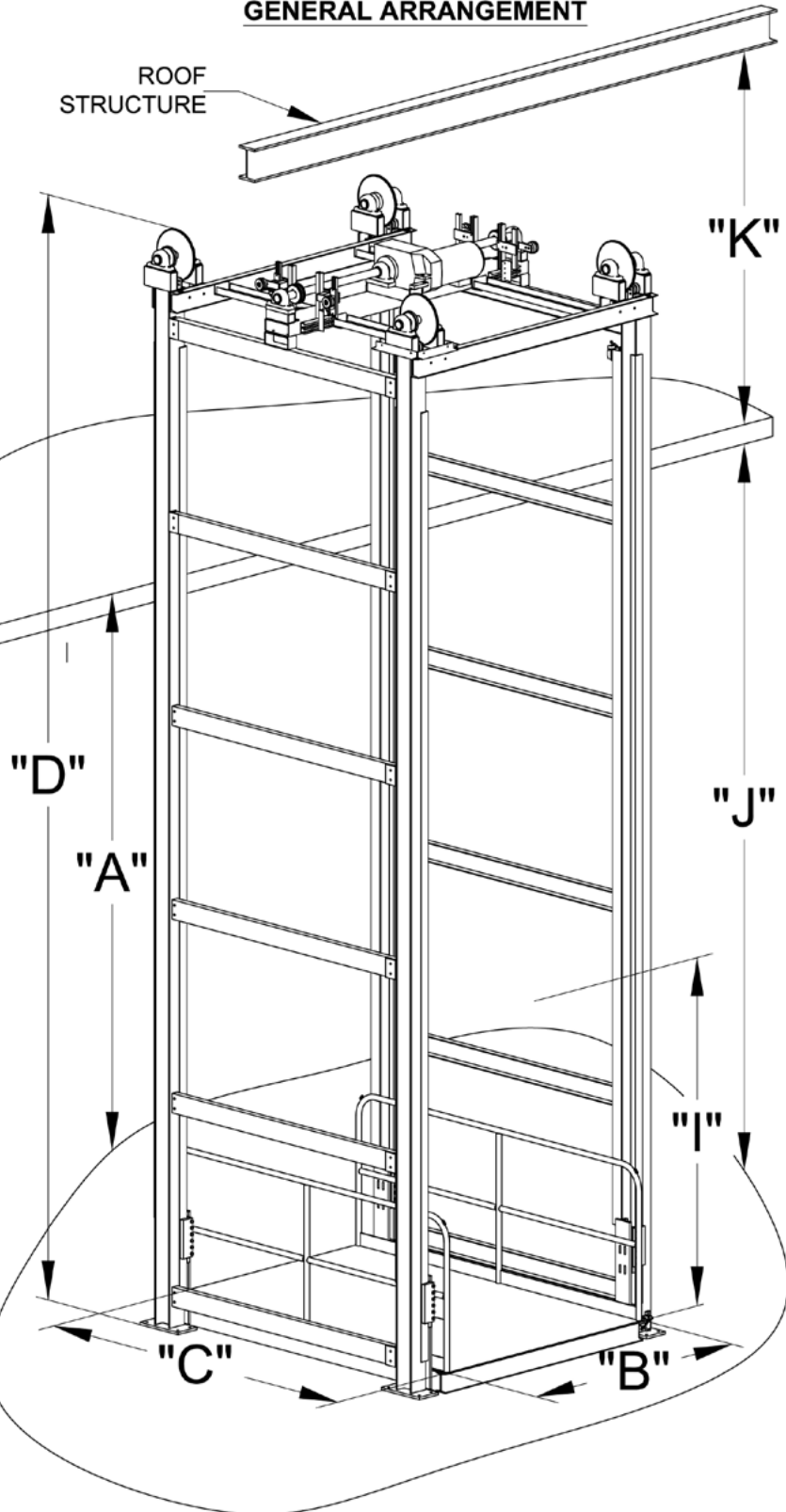

B - CARRIAGE WIDTH - 12'
C - CARRIAGE LENGTH - 40'
I - LOAD HEIGHT - 7'

LIFTING CAPACITY - 8,000lbs

Tacoma Distribution Center

1525 East D Street | Tacoma, WA 98421

For Lease



Contact Us

Monte Decker

Senior Vice President

+1 253 596 0041

monte.decker@cbre.com

Chris Cowles

First Vice President

+1 253 596 0048

chris.cowles@cbre.com

CBRE, Inc.

1201 Pacific Ave

Suite 1502

Tacoma, WA 98402

© 2022 CBRE, Inc. All rights reserved. This information has been obtained from sources believed reliable, but has not been verified for accuracy or completeness. You should conduct a careful, independent investigation of the property and verify all information. Any reliance on this information is solely at your own risk. CBRE and the CBRE logo are service marks of CBRE, Inc. All other marks displayed on this document are the property of their respective owners, and the use of such logos does not imply any affiliation with or endorsement of CBRE. Photos herein are the property of their respective owners. Use of these images without the express written consent of the owner is prohibited. SD 10.11.22